

General Description

XC6206 series are a highly precise, lower consumption, 3 terminal, positive voltage regulators manufactured using CMOS and laser trimming technologies. The series provides large currents with a significantly small dropout voltage.

The XC6206 consists of a current limiter circuit, a driver transistor, a precision reference voltage and an error correction circuit. The series is compatible with low ESR ceramic capacitors. The current limiter's foldback circuit operates as a short circuit protection as well as the output current limiter for the output pin. Output voltages are internally by laser trimming technologies. It is selectable in 0.1V increments within a range of 1.2V to 5.0V. XC6206 series are available in SOT-23, SOT23-3 and SOT-89 packages.

Features

- Low power consumption
- Low voltage drop
- Low temperature coefficient
- Low Quiescent Current: 3 μ A at 6V
- Output voltage accuracy: tolerance $\pm 2\%$

Applications

- Battery-powered equipment
- Reference voltage sources
- Cameras, video cameras
- Portable AV systems
- Mobile phones
- Portable games

Typical Application

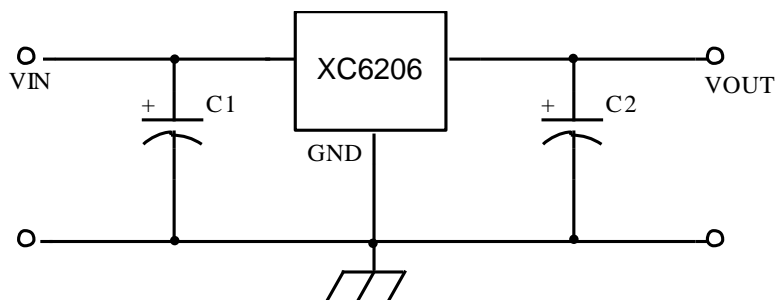

Block Diagram

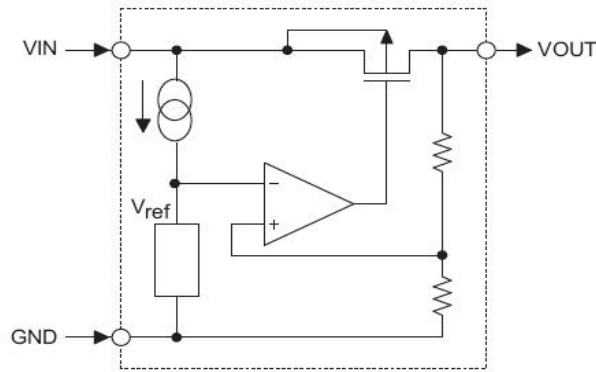

Pin Assignment

**SOT23-3 and SOT23
(Top view)**

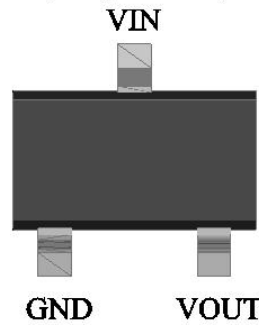

SOT89 A (Top view)

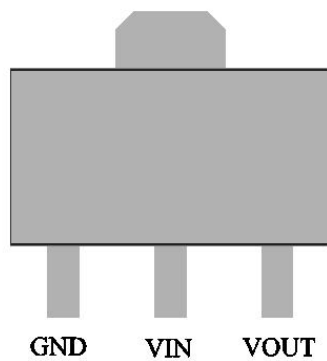

SOT89 B (Top view)

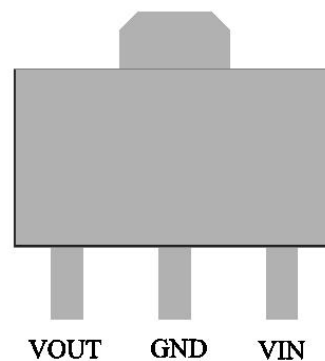

Absolute Maximum Ratings

Parameter		Symbol	Ratings	Units
Input Voltage		V_{IN}	8	V
Output Current		I_{OUT}	300*	mA
Output Voltage		V_{OUT}	$V_{SS}-0.3\sim V_{IN}+0.3$	V
Power Dissipation	SOT-23	P_d	0.20	W
	SOT23-3		0.25	W
	SOT-89		0.50	W
	USP-6B		0.10	W
	TO-92		0.50	W
Operating Temperature Range		T_{opr}	-40~+85	°C
Storage Temperature Range		T_{stg}	-55~+125	°C

$$*I_{OUT}=P_d/(V_{IN}-V_{OUT})$$

Electrical Characteristics

XC6206 for any output voltage ($T_a=25^\circ\text{C}$)

Parameter	Symbol	Conditions	Min.	Typ.	Max.	Unit
Output Voltage	V_{out}	$V_{in}=V_{out}+1V$ $1.0\text{mA}\leq I_{out}\leq 30\text{mA}$	$V_{out}\times 0.98$	--	$V_{out}\times 1.02$	V
Output Current*1	I_{out}	$V_{in}-V_{out}=1V$	--	300	--	mA
Low dropout*2	V_{drop}	Refer to the next table				
Line Regulation	$\Delta V_{out1}/(V_{in}-V_{out})$	$1.6V\leq V_{in}\leq 8V$ $I_{out}=40\text{mA}$	--	0.05	0.2	%/V
Load Regulation	$\Delta V_{out}/\Delta I_{out}$	$V_{in}=V_{out}+1V$ $1.0\text{mA}\leq I_{out}\leq 80\text{mA}$	--	12	30	mV
Output voltage Temperature Coefficiency	$\Delta V_{out}/(T_a-V_{out})$	$I_{out}=30\text{mA}$ $0^\circ\text{C}\leq T_a\leq 70^\circ\text{C}$	--	± 100	--	Ppm/°C
Supply Current	I_{ss}	--	--	3	5	μA
Input Voltage	V_{in}	--	--	6	8	V
PSRR	PSRR	$F=1\text{KHz}$ $V_{in}=V_{out}+1V$	--	50	--	dB
Output Noise	EN	$BW=10\text{Hz}\sim 100\text{KHz}$	--	30	--	μVrms

Electrical Characteristics by Output Voltage:

Output Voltage $V_{out}(V)$	Dropout Voltage V_{dif} (V)		
	Conditions	Typ.	Max.
$V_{out}\leq 1.5V$	$I_{out}=100\text{mA}$	0.35	0.57
$1.8\leq V_{out}\leq 2$		0.28	0.42
$2.8\leq V_{out}\leq 5.0$		0.19	0.35

Package Information
3-pin SOT23 Outline Dimensions

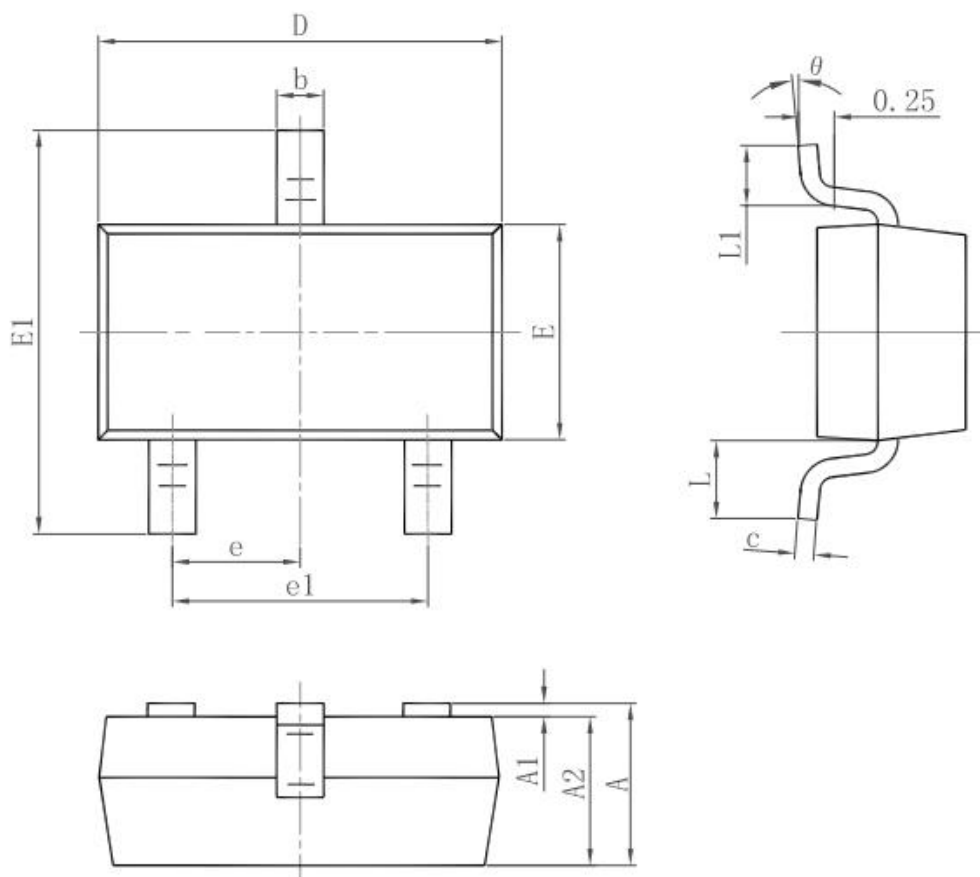

Symbol	Dimensions In Millimeters		Dimensions In Inches	
	Min.	Max.	Min.	Max.
A	0.900	1.150	0.035	0.045
A1	0.000	0.100	0.000	0.004
A2	0.900	1.050	0.035	0.041
b	0.300	0.500	0.012	0.020
c	0.080	0.150	0.003	0.006
D	2.800	3.000	0.110	0.118
E	1.200	1.400	0.047	0.055
E1	2.250	2.550	0.089	0.100
e	0.950 TYP.		0.037 TYP.	
e1	1.800	2.000	0.071	0.079
L	0.550 REF.		0.022 REF.	
L1	0.300	0.500	0.012	0.020
θ	0°	8°	0°	8°

3-pin SOT23-3 Outline Dimensions

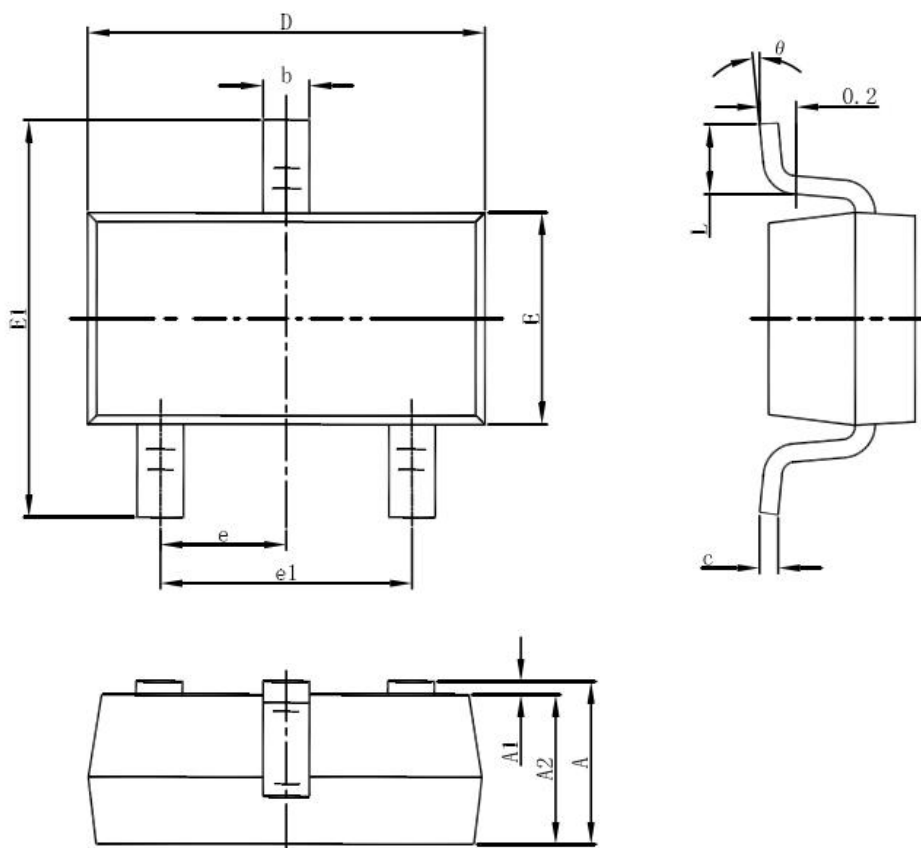

Symbol	Dimensions In Millimeters		Dimensions In Inches	
	Min	Max	Min	Max
A	1.050	1.250	0.041	0.049
A1	0.000	0.100	0.000	0.004
A2	1.050	1.150	0.041	0.045
b	0.300	0.500	0.012	0.020
c	0.100	0.200	0.004	0.008
D	2.820	3.020	0.111	0.119
E	1.500	1.700	0.059	0.067
E1	2.650	2.950	0.104	0.116
e	0.950(BSC)		0.037(BSC)	
e1	1.800	2.000	0.071	0.079
L	0.300	0.600	0.012	0.024
θ	0°	8°	0°	8°

3-pin SOT89 Outline Dimensions

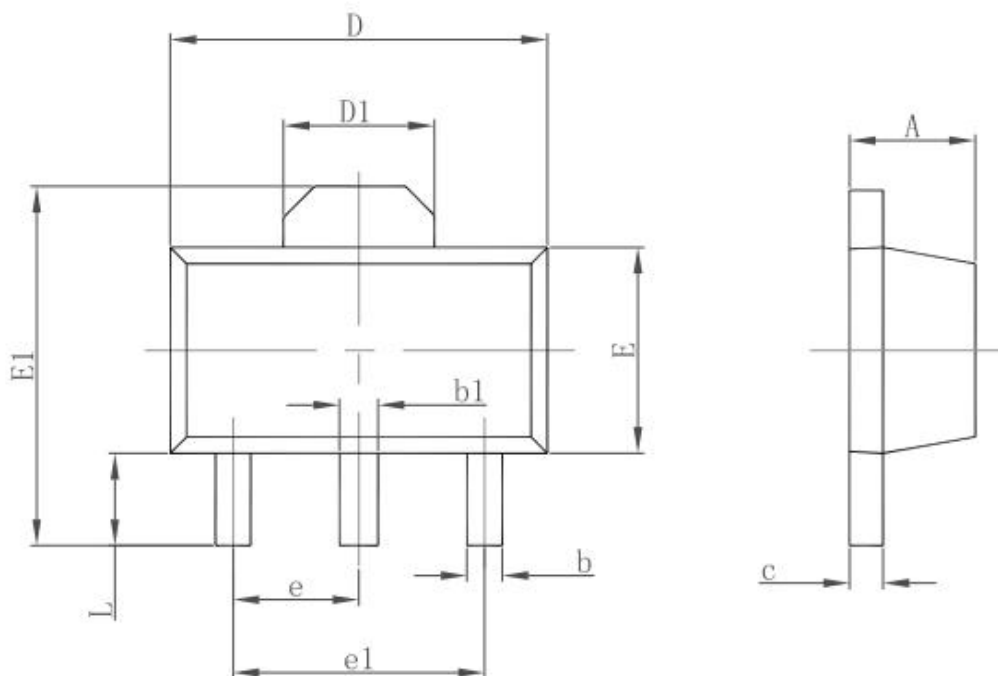

Symbol	Dimensions In Millimeters		Dimensions In Inches	
	Min.	Max.	Min.	Max.
A	1.400	1.600	0.055	0.063
b	0.320	0.520	0.013	0.020
b1	0.400	0.580	0.016	0.023
c	0.350	0.440	0.014	0.017
D	4.400	4.600	0.173	0.181
D1	1.550 REF.		0.061 REF.	
E	2.300	2.600	0.091	0.102
E1	3.940	4.250	0.155	0.167
e	1.500 TYP.		0.060 TYP.	
e1	3.000 TYP.		0.118 TYP.	
L	0.900	1.200	0.035	0.047